



DESIGN EVOLUTION OF ANTENNA SYSTEMS FOR DTV MULTICHANNEL OPERATION

- 1.- An Improved Constant Impedance Channel Combiner for UHF TV (MCI)
- 2.- UHF CPOL/EPOL Panel antenna to ensure mobile-handheld reception (RYMSA)

An Improved Constant Impedance Channel Combiner for UHF TV

Presented by Frank Malanga

Micro Communications, Inc.
Merrimack, New Hampshire
A RYMSA Company



Agenda

- Review
 - Different types of channel combiners.
 - Constant-impedance channel combiner (CICC) fundamentals.
- Tutorial
 - The critical role of the hybrid in a CICC.
- New
 - Improved performance of a new 90° coax hybrid designed for wideband, high power channel combining.
 - An Improved Constant Impedance Channel Combiner for UHF TV

Various Types of Channel Combiners

Tee-based Combiners

- Starpoint
- Manifold

Hybrid-based Combiners

- Constant Impedance

Tee-based Combiners

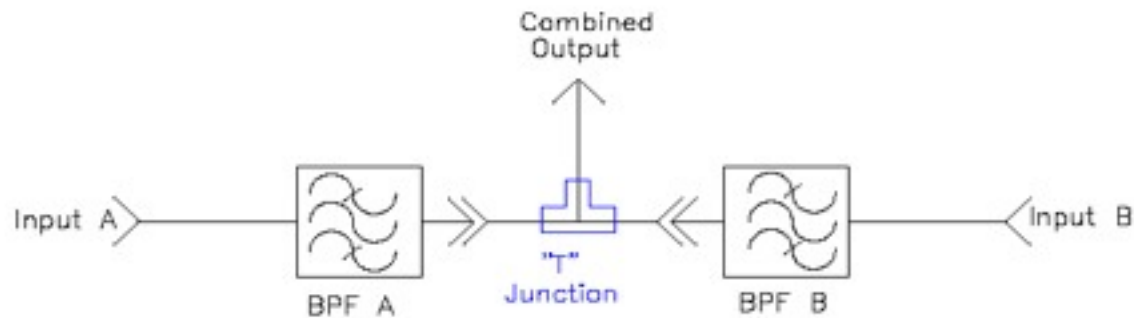

Unitary Tee-junction Combiner

- Starpoint and manifold channel combiners are both composed of the unitary Tee-junction combiners.

Unitary Tee-junction Combiner Channel A Perspective

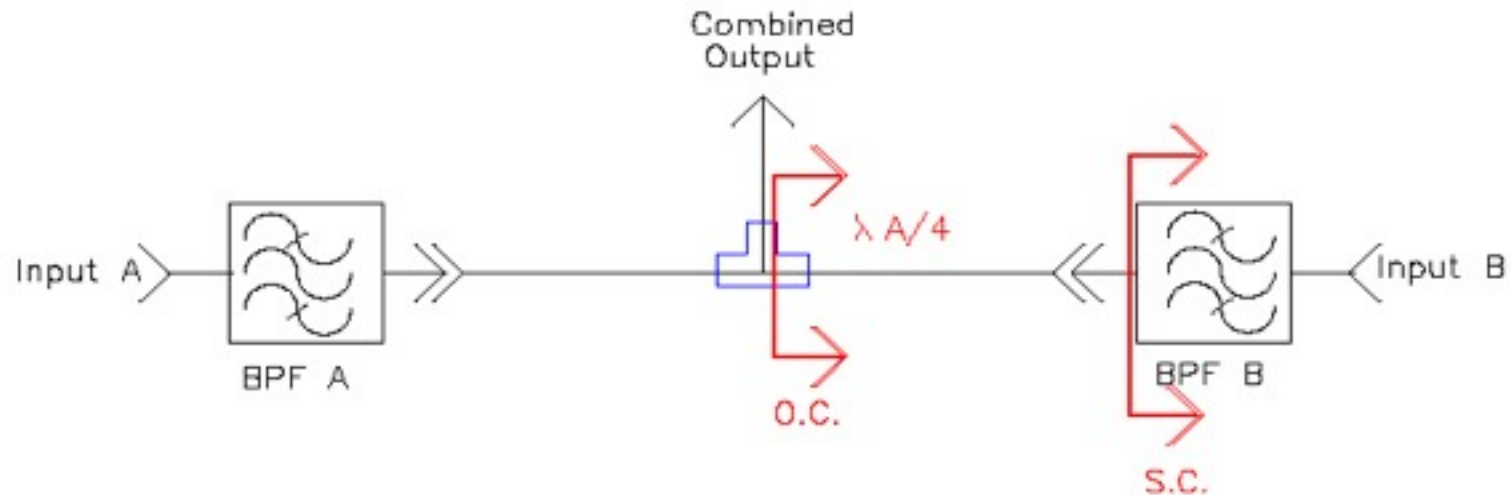

- BPF-B acts as a short-circuit to Channel A
- One-quarter wavelength before a short circuit is a virtual open circuit
- This open circuit condition effectively decouples the entire “B” branch of the circuit from the tee junction.

Tee-junction Combiner (Channel A perspective)

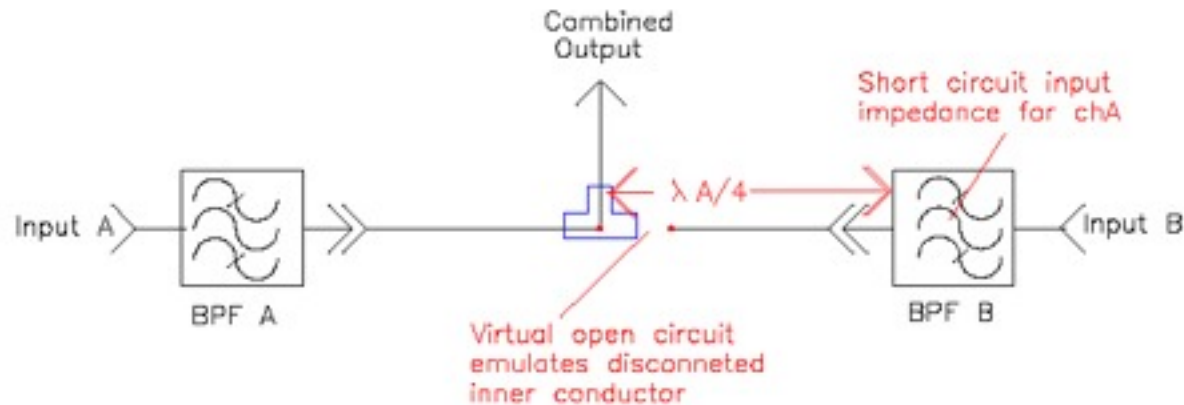

- A virtual open circuit condition (no current flow) precisely located at the tee junction is effectively similar to disconnecting the inner conductor that leads to filter BPF-B.
- Thus the tee junction with a properly phased reflective filter behaves like an elbow and all power flows to the common output port.

T-junction Combiner General Solution

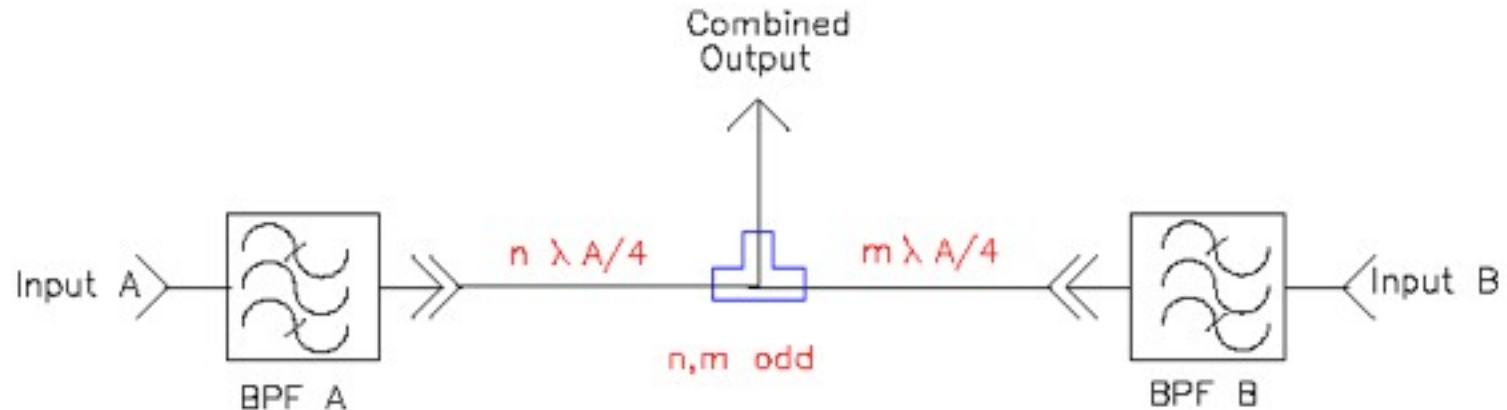

- The line length from BPF-A to the tee junction is critical to channel B and of no consequence to channel A.
- The line length from BPF-B to the tee junction is critical to channel A and of no consequence to channel B.
- Half wavelengths can be added to the phasing lines and the combiner will still work, but with reduced bandwidth. (The critical phasing lines are $\lambda/4$ long at only one center frequency).

Multichannel Tee-junction “Starpoint” Combiners

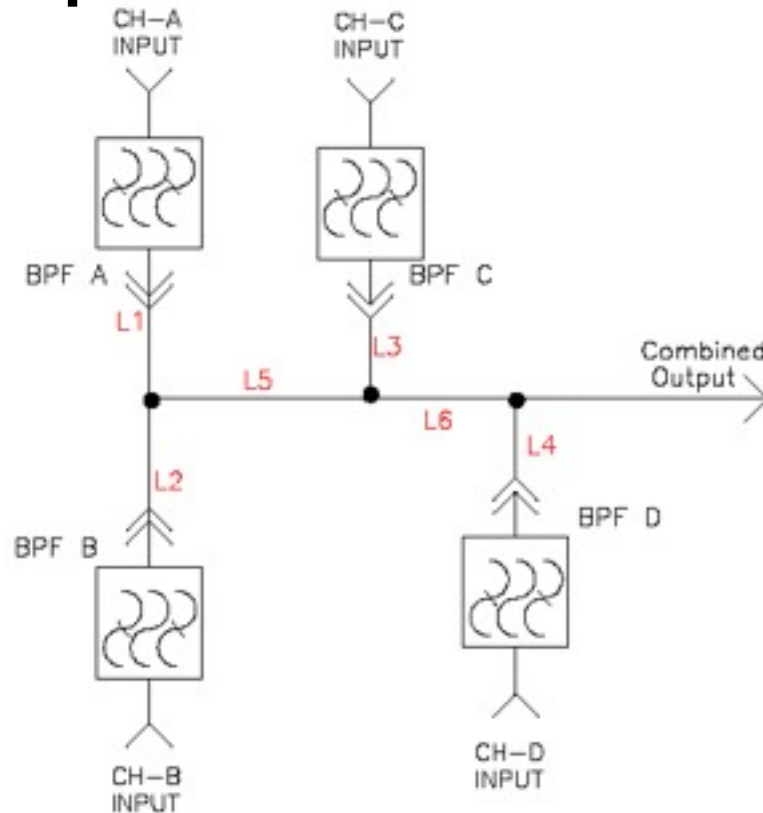

- Multiple channels can be combined in the same way using multiple tees and multiple phasing lines.

Manifold Combiners

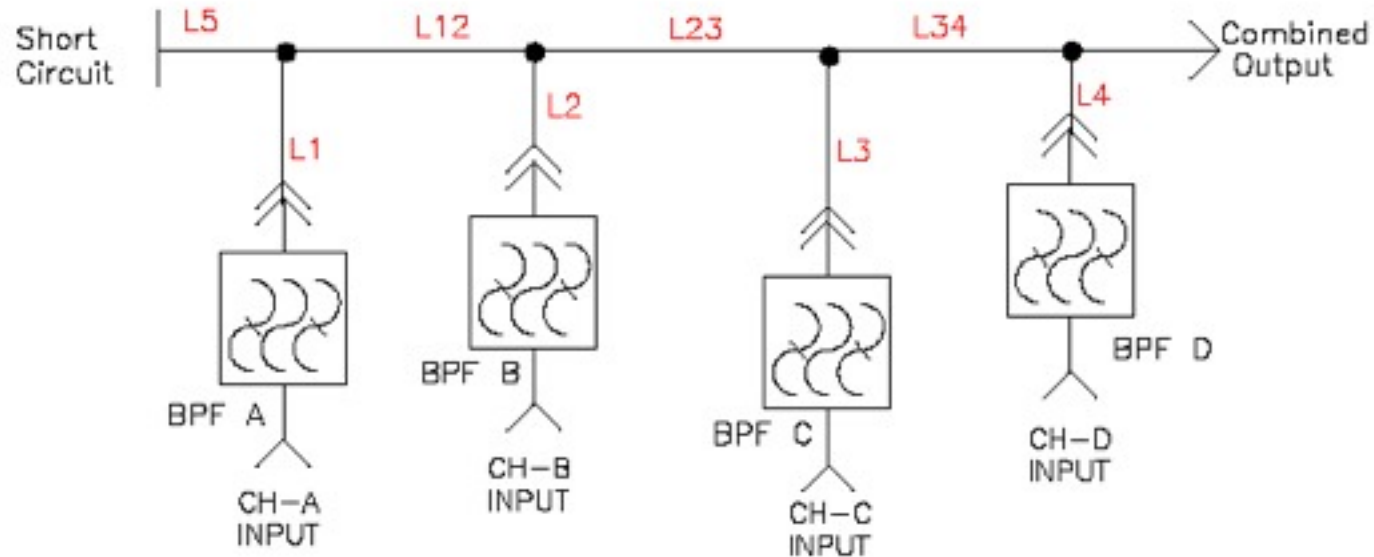

- A manifold combiner is simply a multi-channel tee-combiner with all of the tees lined up in a serial, collinear fashion.

Manifold/Starpoint Combiners

- Can be very compact, with the least hardware for any type of channel combiner.
- Typically lower cost than constant impedance channel combiners.
- Will reflect out-of-band power back to each transmitter.
- Lowest VSWR for any type of channel combiner for multiple widely-spaced channels. (No hybrid)
- Complicated design, very hard to tune the prototype if it is not accurately designed.
- Not future-expandable. (But it can be fed into the wideband input port of a downstream constant-impedance channel combiner.)

Four Channel Starpoint Combiner

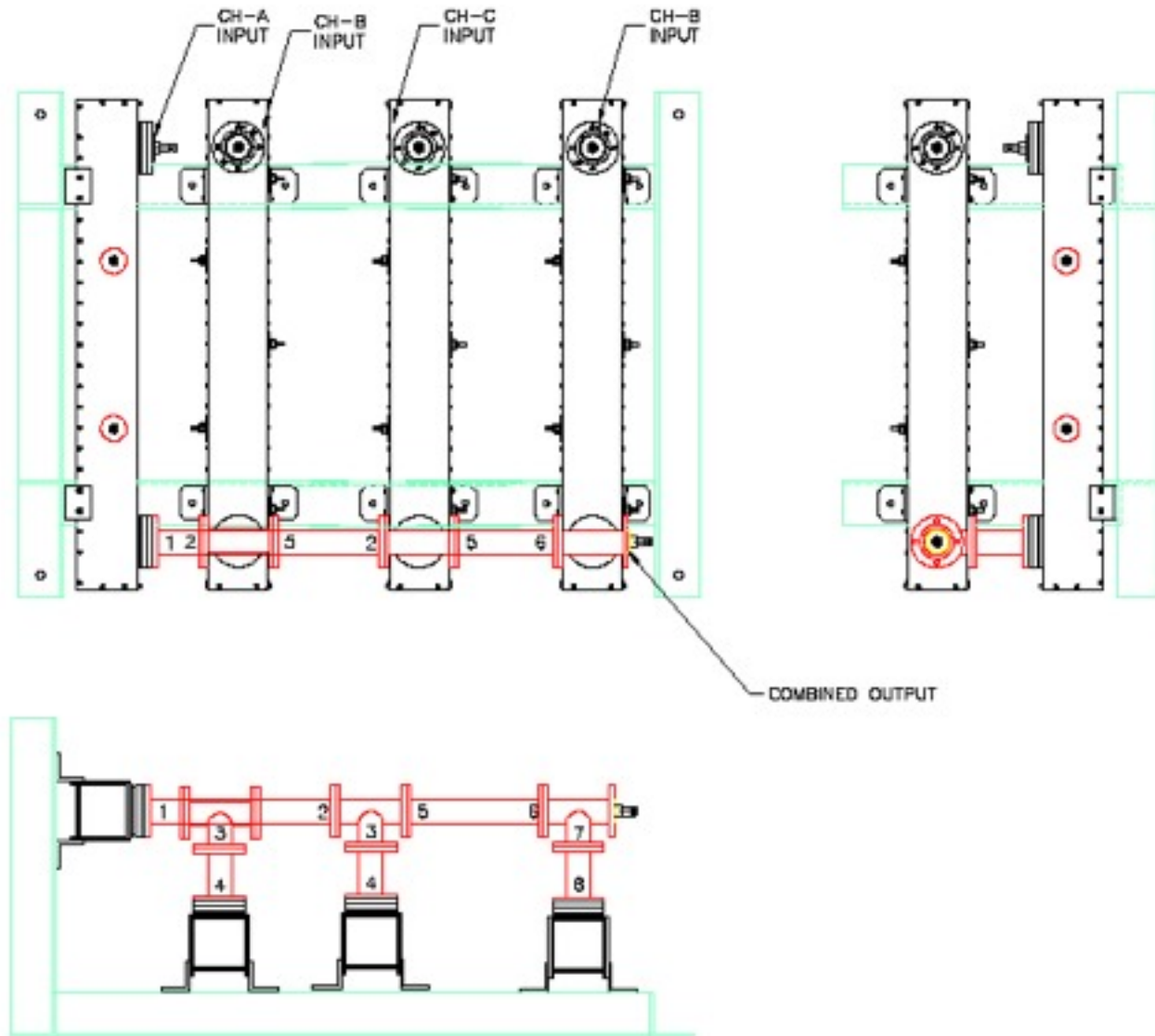

Five-channel

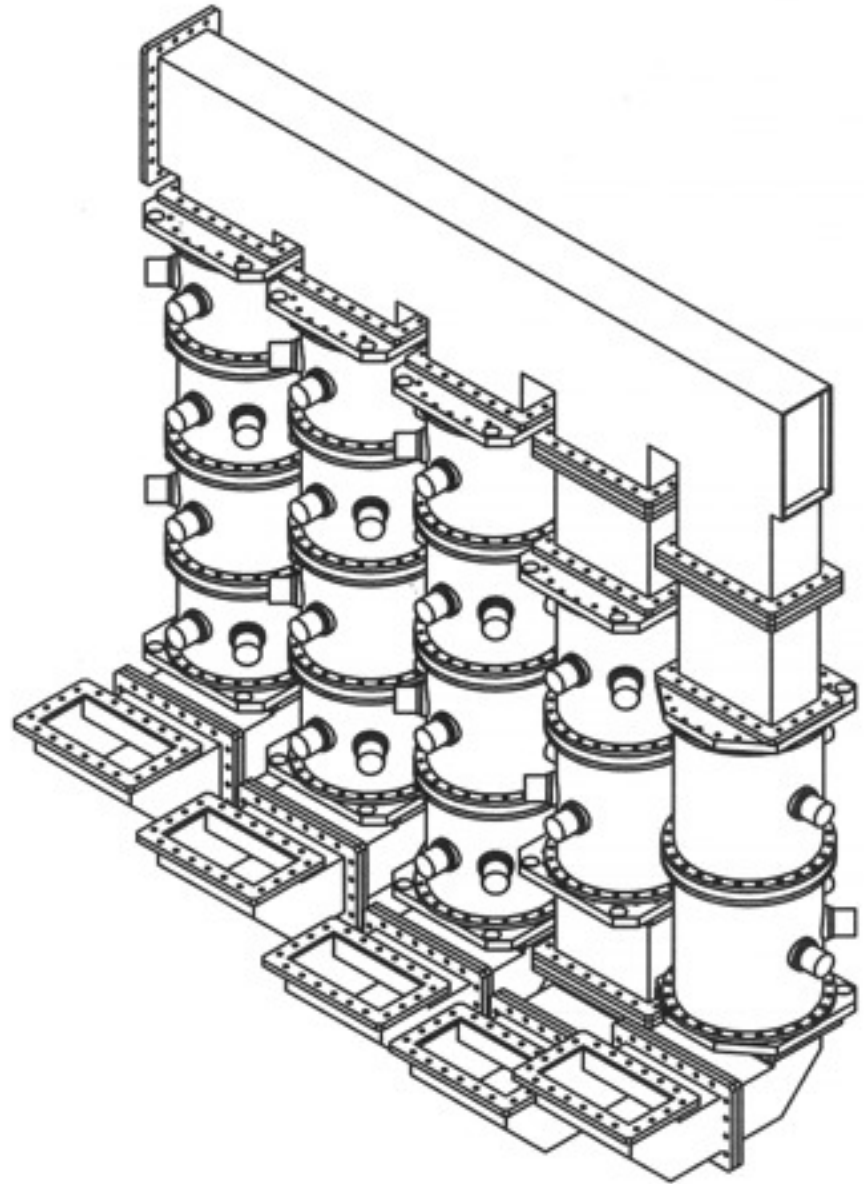

Constant Impedance (Balanced) Channel Combiners

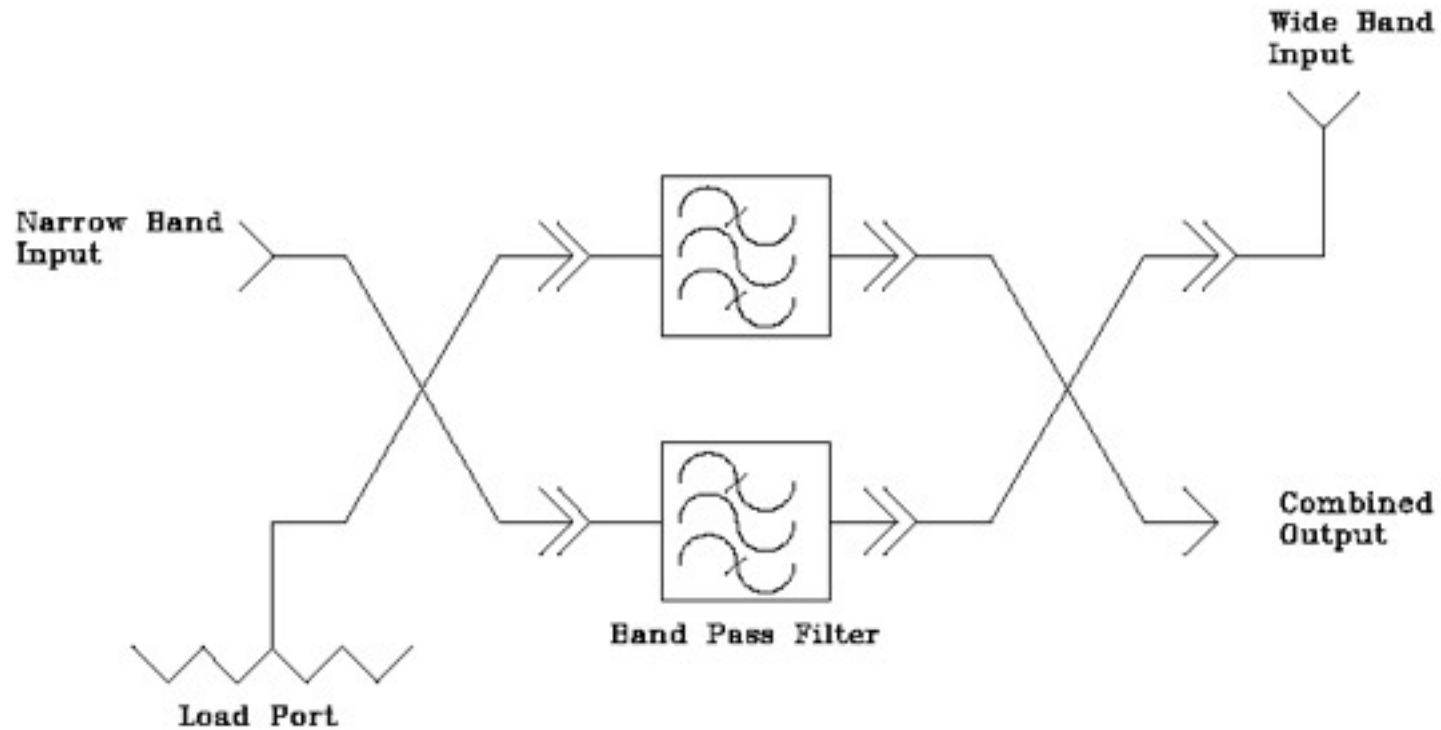

CICC Narrowband Signal Flow

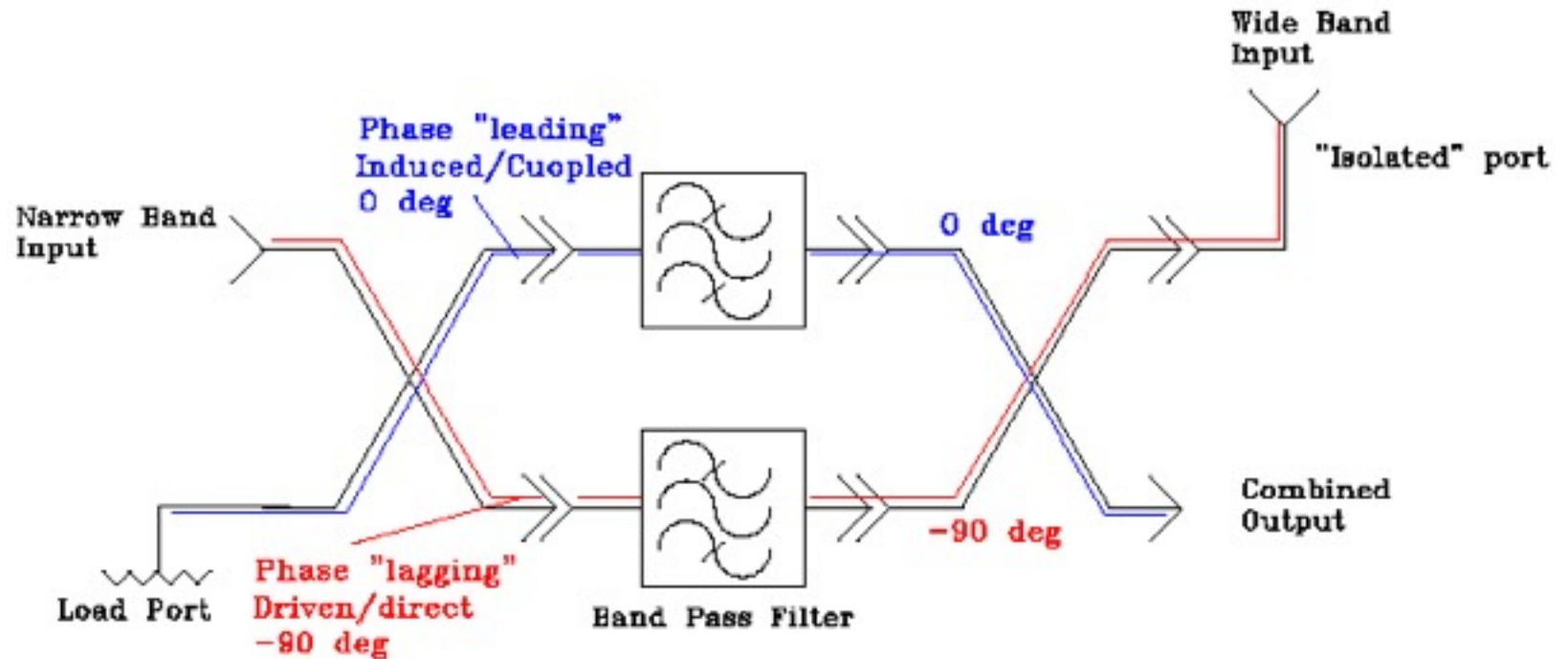

CICC Wideband Flow to Filters

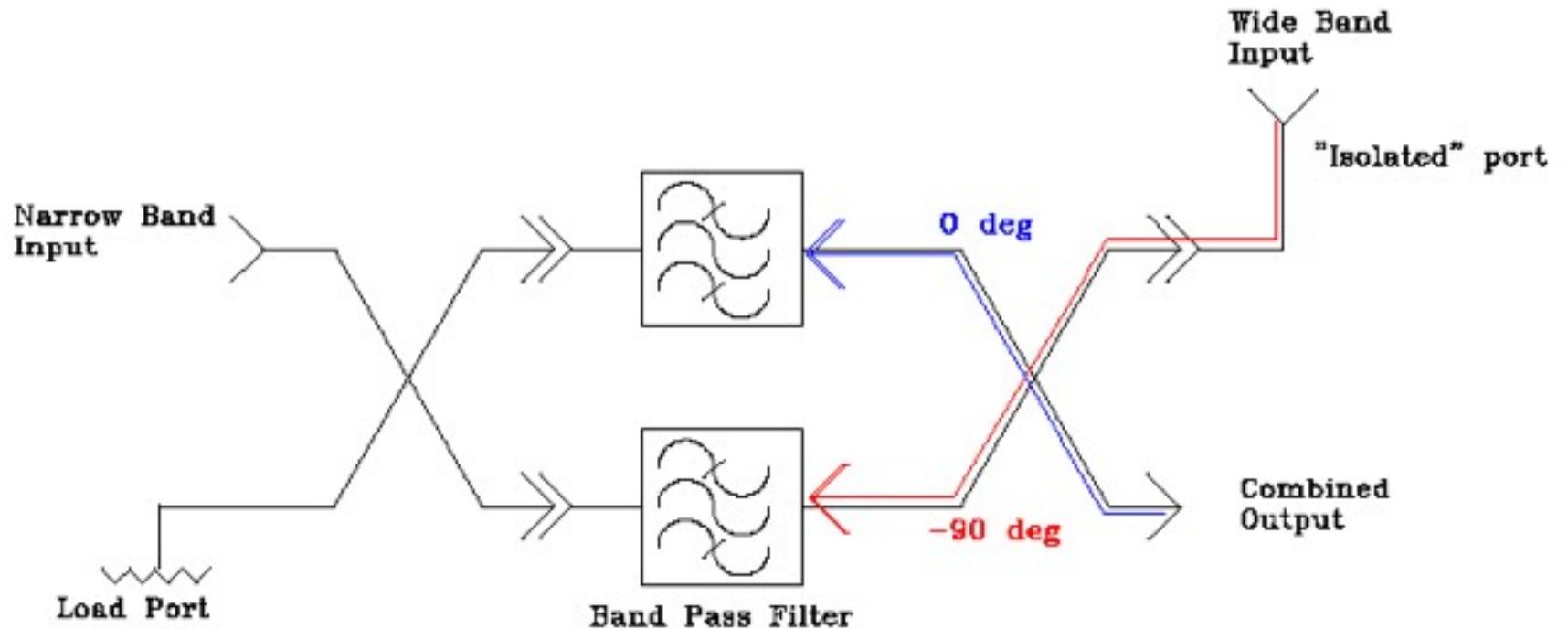

CICC Wideband Flow off Filters

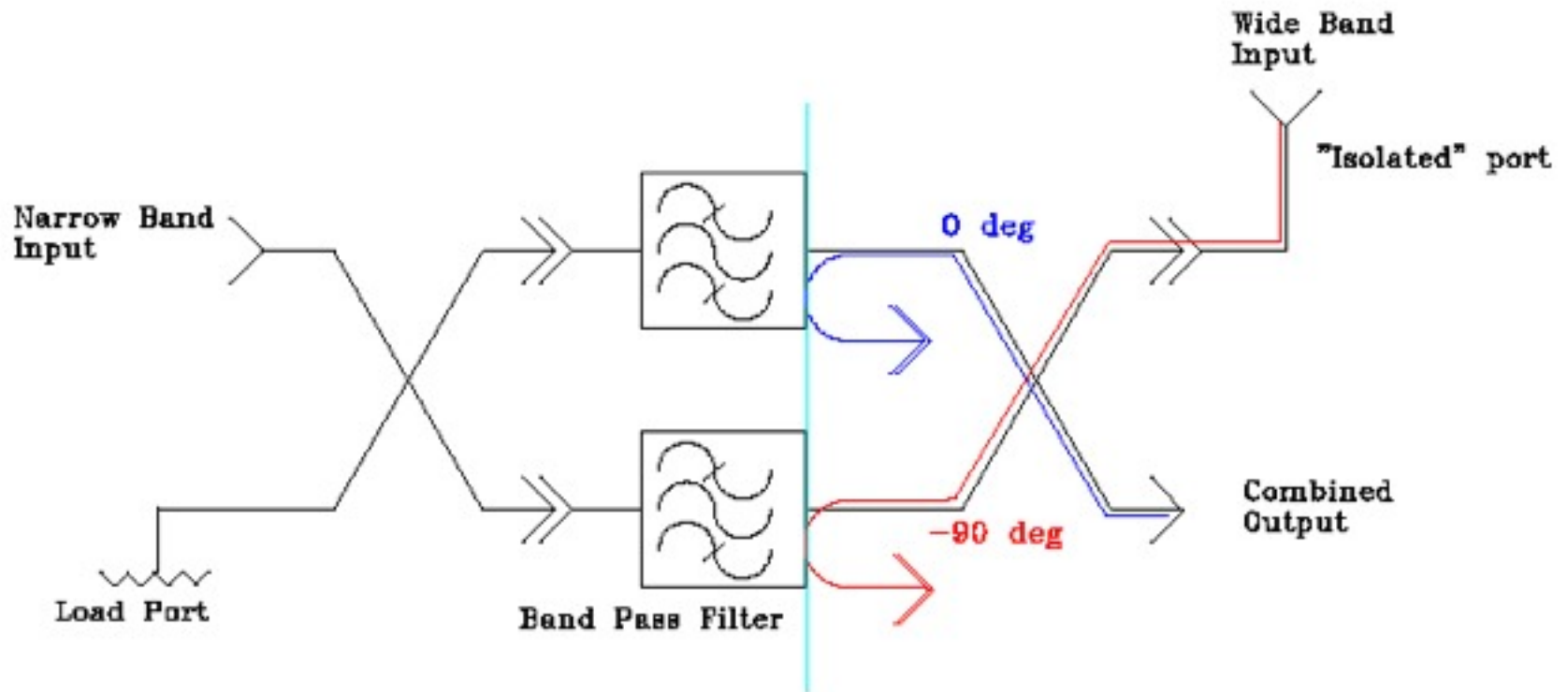

Constant Impedance (Balanced) Channel Combiners

- CICC's present wideband *matched* impedances at both the narrowband and wideband inputs.
- Each CICC module adds a single new channel to a pre-existing multiplex of channels.
- CICC's are modular and can be cascaded with other CICC modules.

The Role of the Hybrid in a Constant Impedance Channel Combiner

The Role of the Hybrid in a Constant Impedance Channel Combiner

- Splitting signals with a hybrid.
- Combining equal-power “half-signals” with a hybrid.
- The “short-circuit” VSWR of a hybrid as an estimator of combiner VSWR at the wideband input port.

Splitting Signals With a Hybrid

Input, 100%, 0°

Direct Output, 50%, -90°

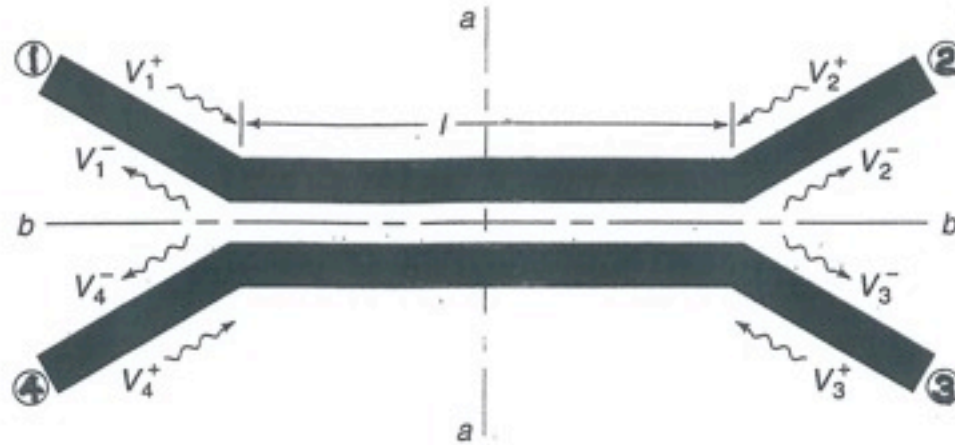

Coupled Output, 50%, 0°

Isolated Port

Combining Signals With a Hybrid

Isolated Port

Input 50%, -90°

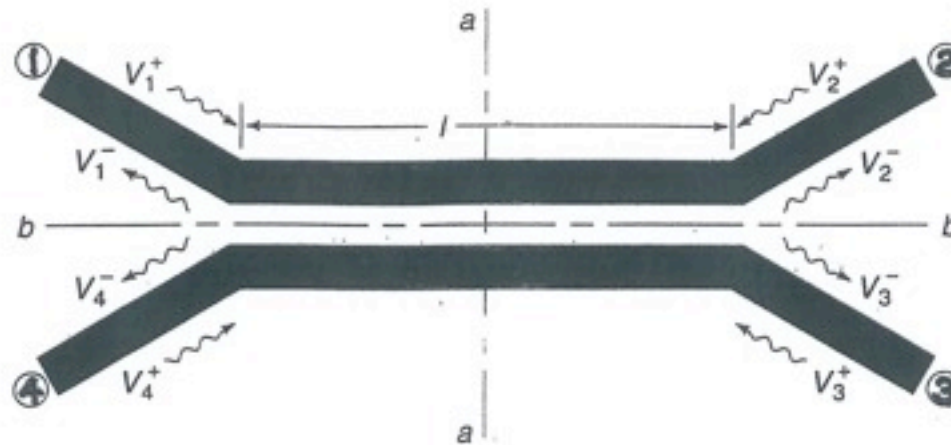

Input, 50%, 0°

Output 100%, -90°

Hybrid Amplitude Split and its Frequency Dependence

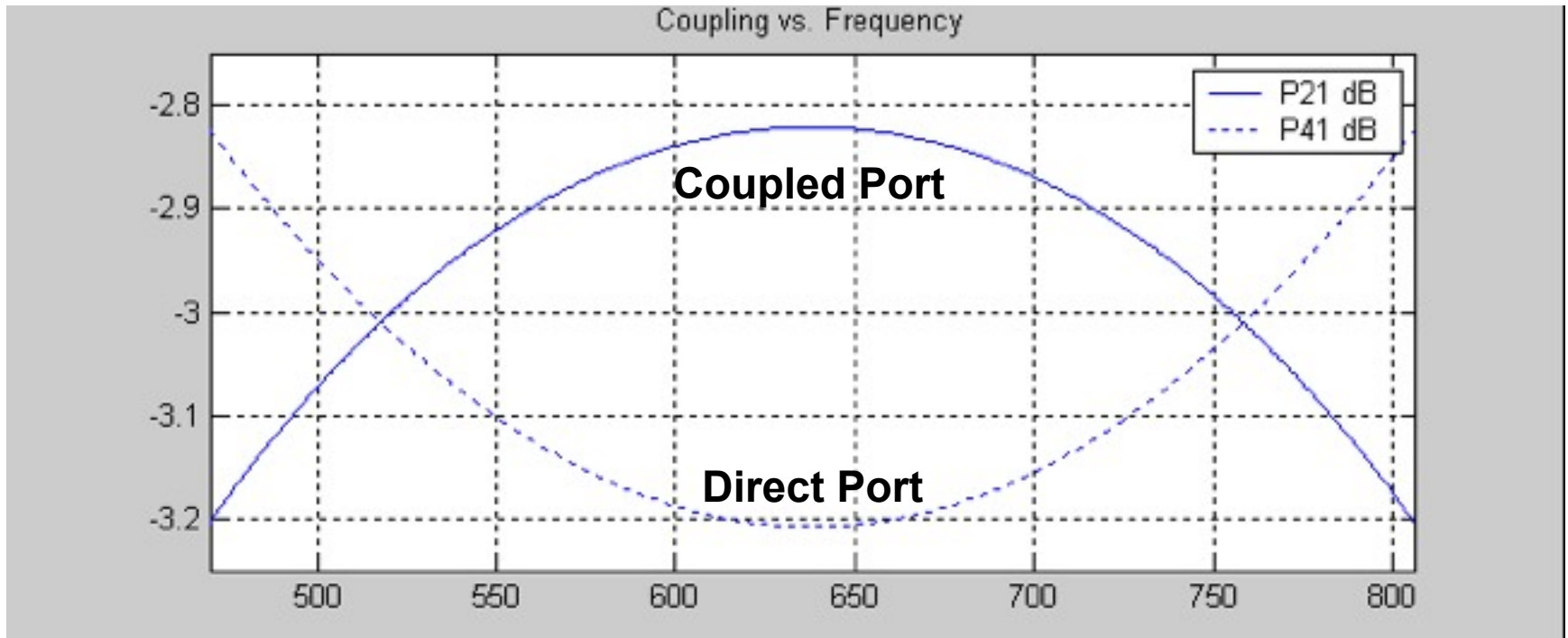

- **Broadband coupling of a quarter-wave hybrid**
- **The amplitude-imbalance is equalized across the band.**

Short Circuited, Over-coupled Hybrid

100% Input Power
Reflected 2.2%
16.5 dB RL
1.35 VSWR

47.8%, -90°, reflected back

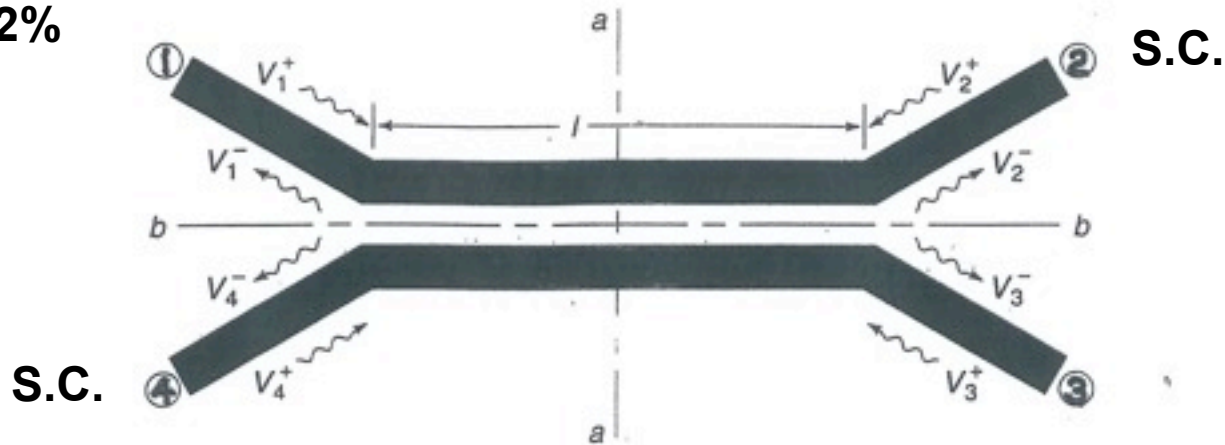

52.2%, 0°, reflected back

Output ?

“Short Circuit” VSWR

- Wideband signals entering a CICC are reflected by the filter and are recombined by the wideband hybrid.
- If the amplitude split of the hybrid is not a perfect -3.01 dB, then there will be some reflected power at the wideband input.
- This is essentially the same as the short-circuit VSWR of the hybrid, assuming filters are well matched.
- Thus, having a flatter amplitude split will lead to a CICC with better wideband input VSWR.

An Improved Hybrid

- The limitation of the quarter wave hybrid is its amplitude split versus frequency which is always the same cosine-squared shape.
- MCI has developed a multi-step hybrid that has flatter amplitude split and thus lower short-circuit VSWR

Amplitude Split of Super-hybrid (multi steps)

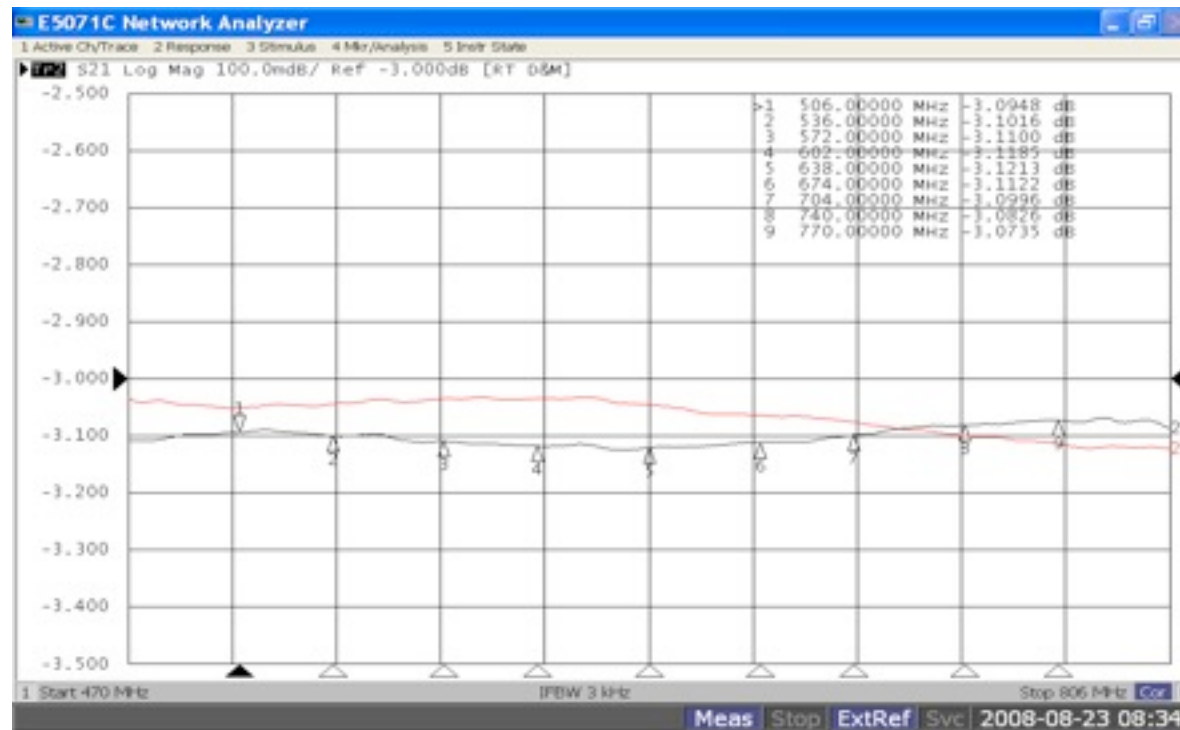

- Only 0.08 dB maximum imbalance compared with 0.40 dB with a quarter-wave hybrid.
- This indicates 0.5% reflected power in short-circuit conditions, 23 dB RL,
- 1.15 VSWR as compared with 16.5 dB RL and 1.35 VSWR for standard hybrid.

E5071C Network Analyzer

1 Active Ch/Trace 2 Response 3 Stimulus 4 Mkr/Analysis 5 Instr State

Tr2 S21 Log Mag 100.0mdB/ Ref -3.000dB [RT D&M]

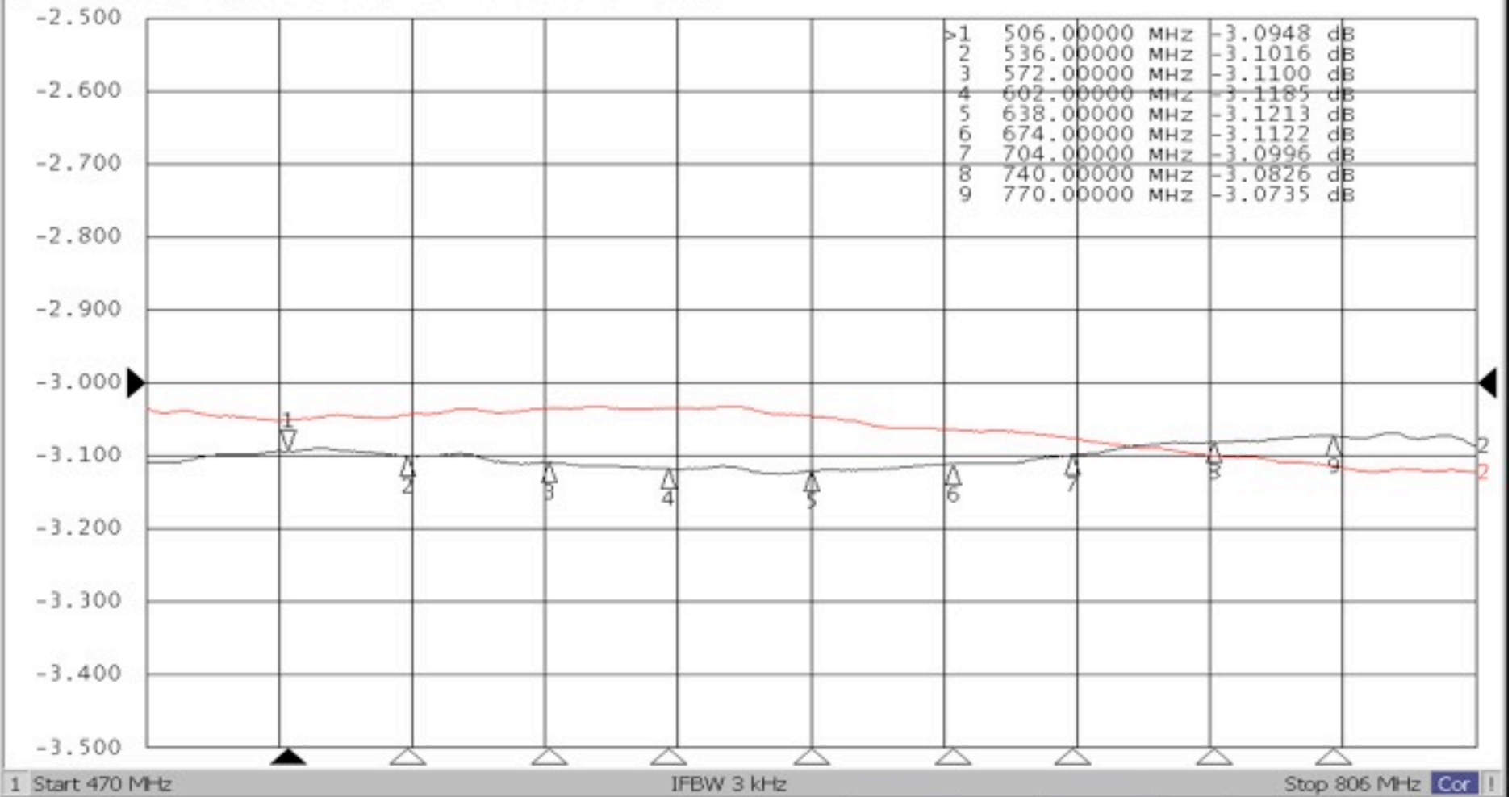

1 Start 470 MHz IFBW 3 kHz Stop 806 MHz Cor |

Meas Stop ExtRef Svc 2008-08-23 08:34

S.C. VSWR of Super-Hybrid

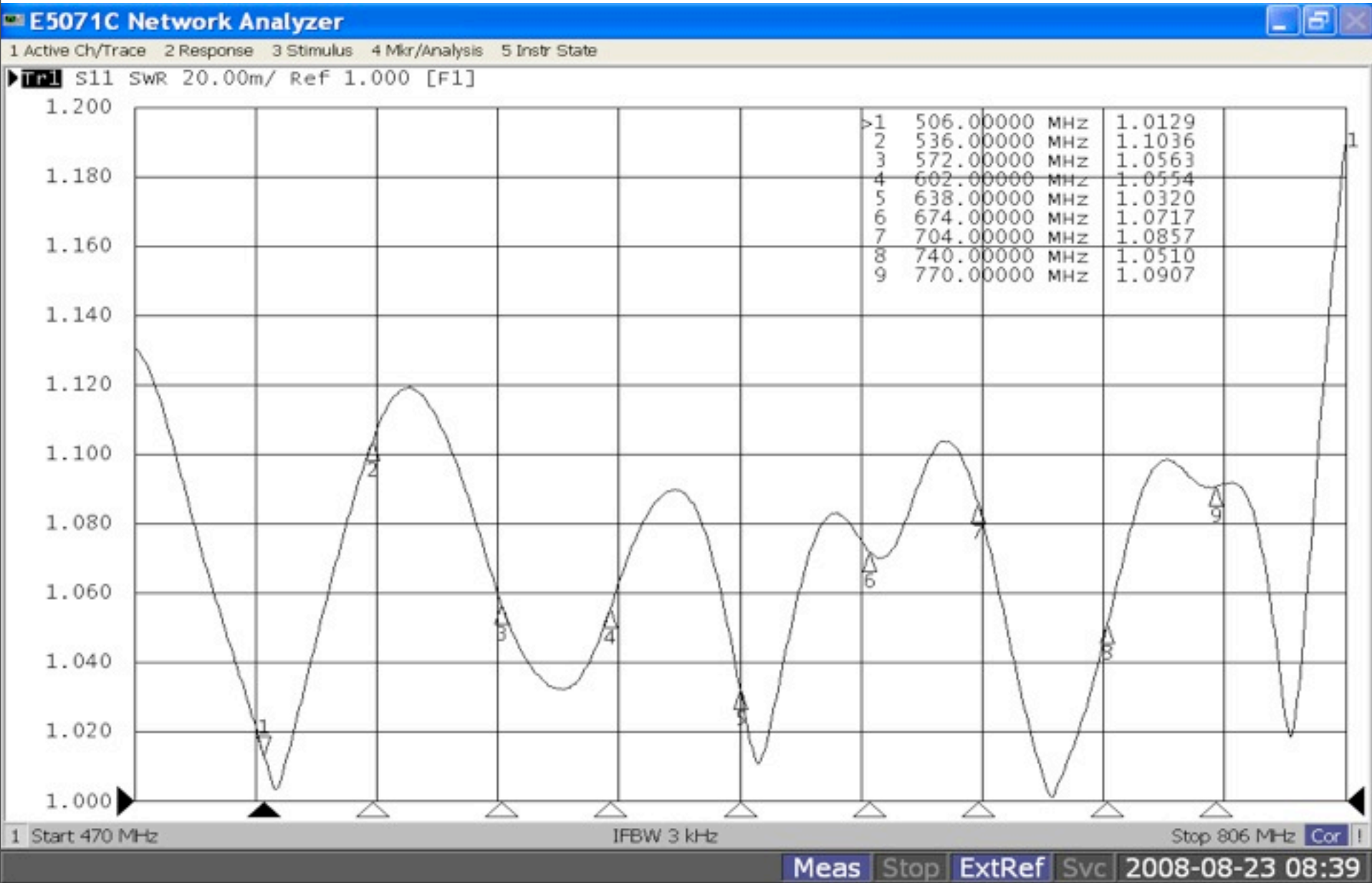

MCI new Superhybrid

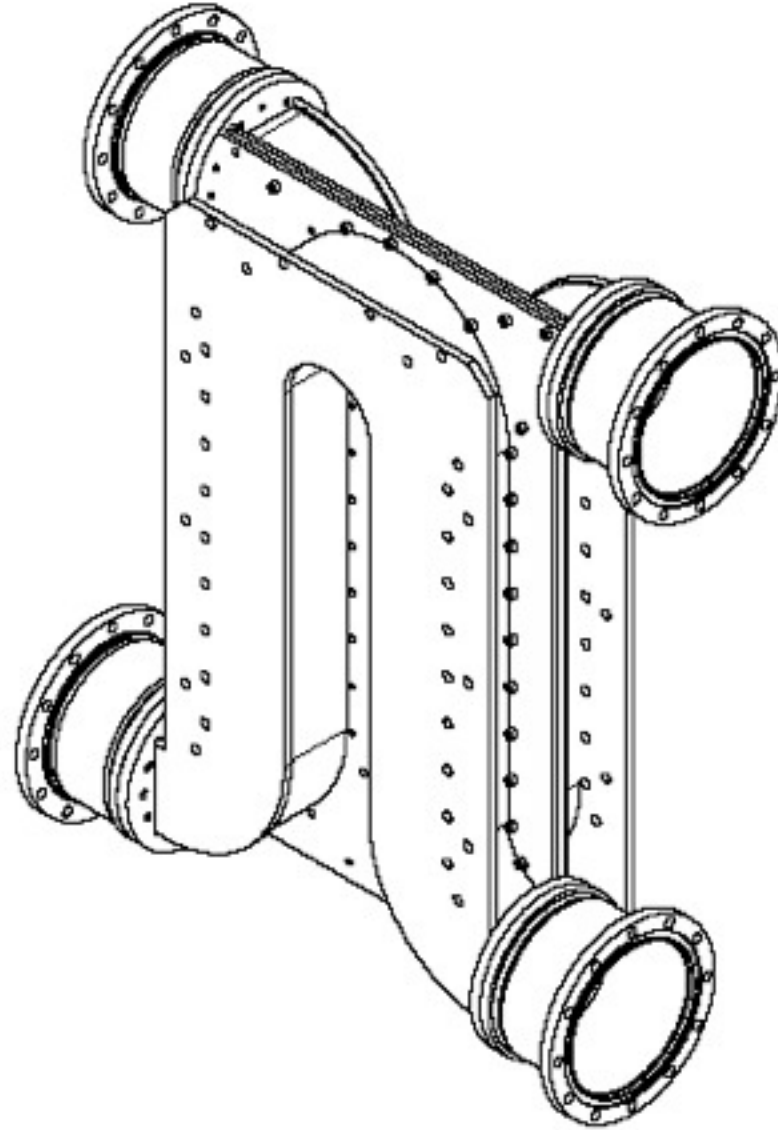

We have used our new Superhybrid with great results on three high power projects.

→ IonMedia Combiner, NB=ch22 at 48KW

WB = ch42, 54 & 55 at 15KW

→ VTC Combiner, NB=ch39 at 34KW

WB = ch33,34,38, 54, 60 & 61 at 65KW

→ Poland Combiner, NB= ch27&44 at 60KW

WB = ch33,41,48,51,55 &58 at 15KW

Ion Media CICC with Superhybrids

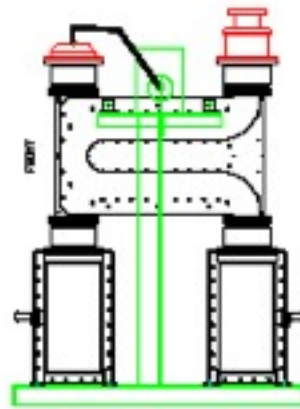
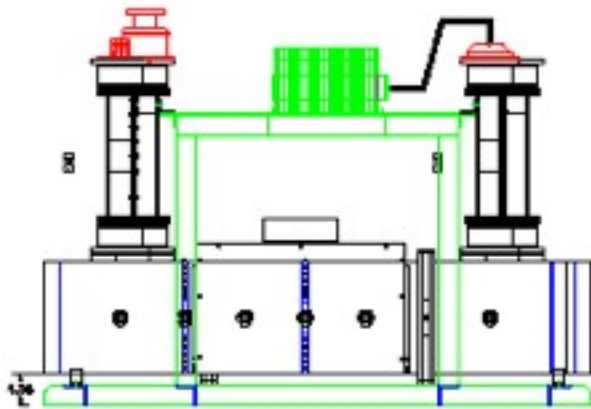
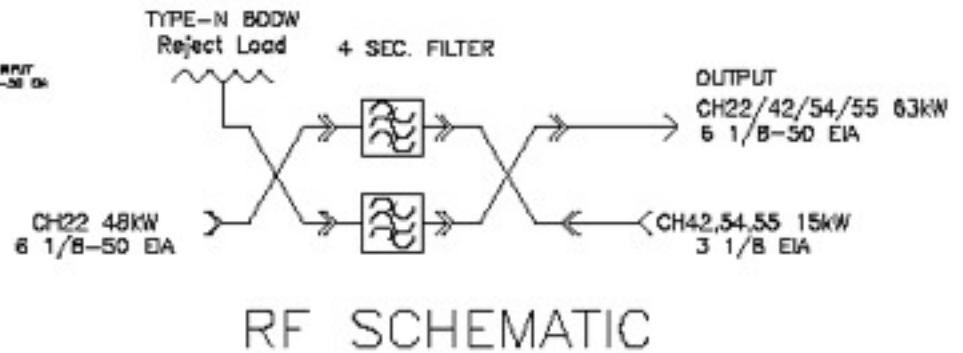
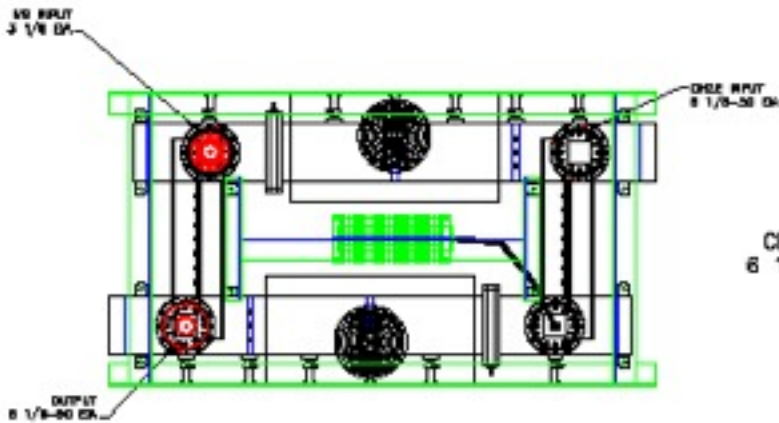

S11 SwR 20.00m/ Ref 1.000 [F1]

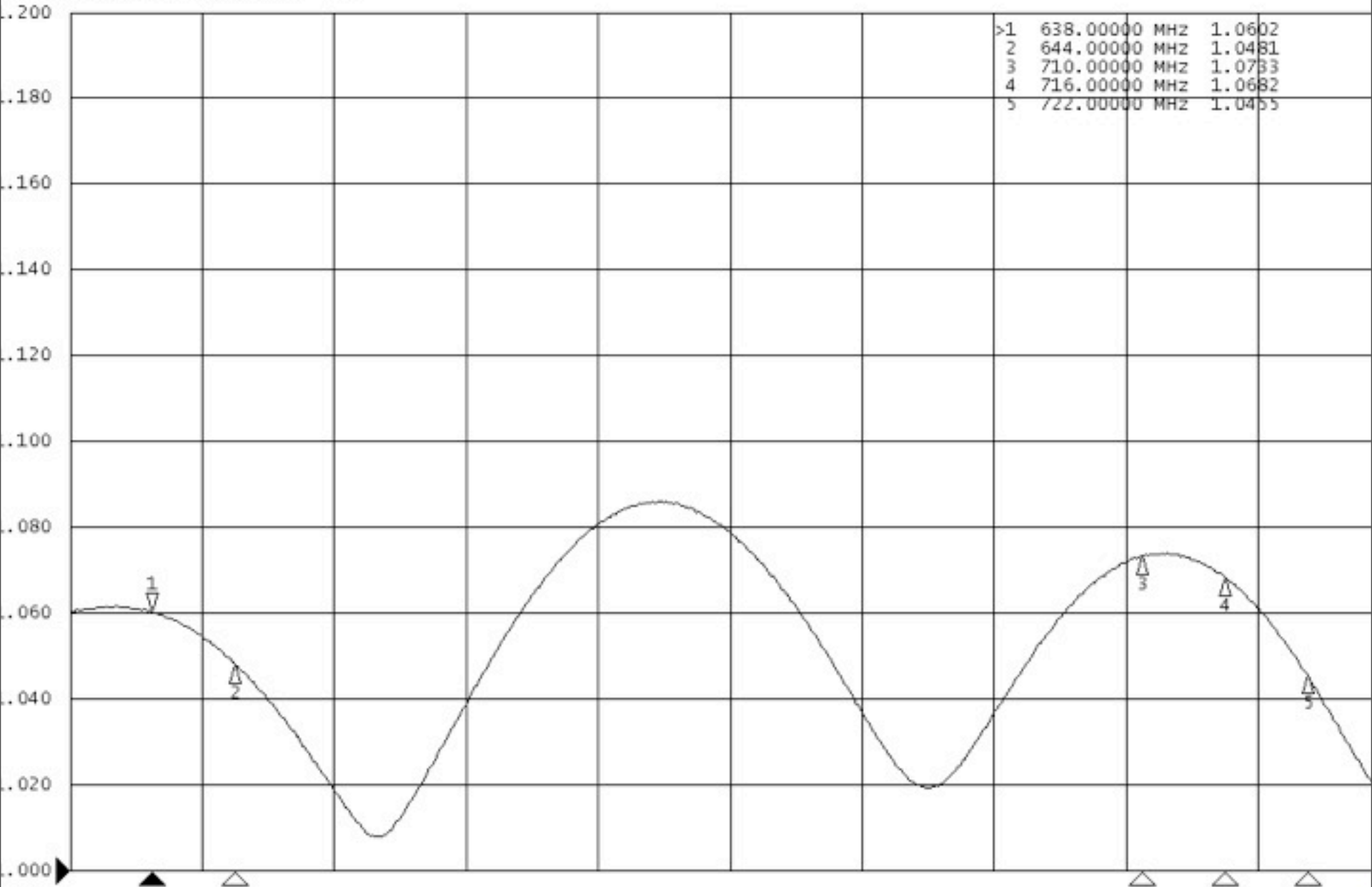

Start 632 MHz IFBW 3 kHz Stop 728 MHz

Can Tho Combiner 41276-8DMF-FB

6-1/8 CIBP-8DMF 2CH COMBINER

216133D-6325

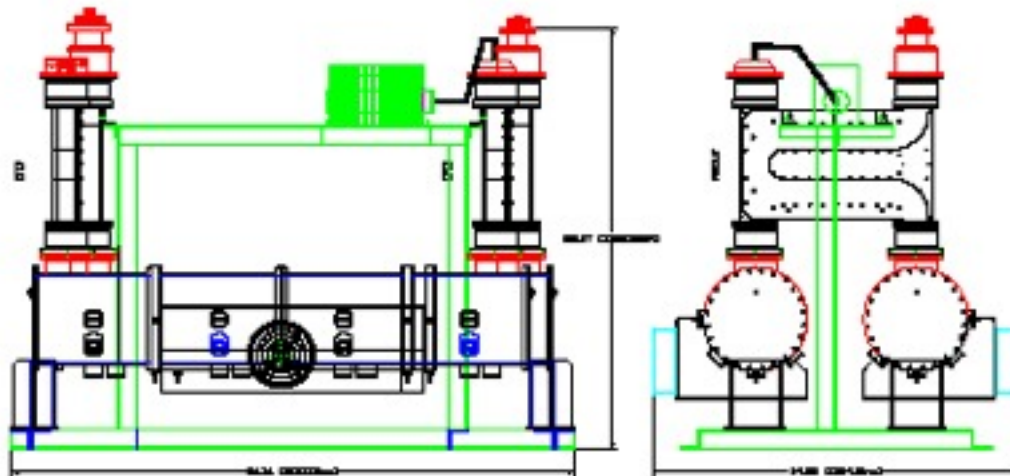
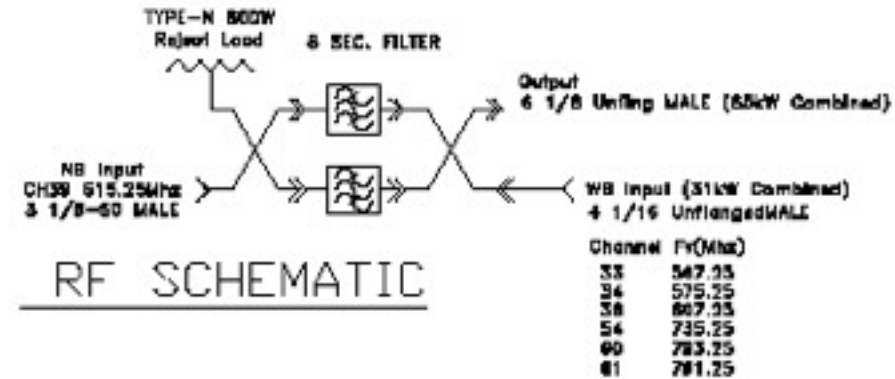
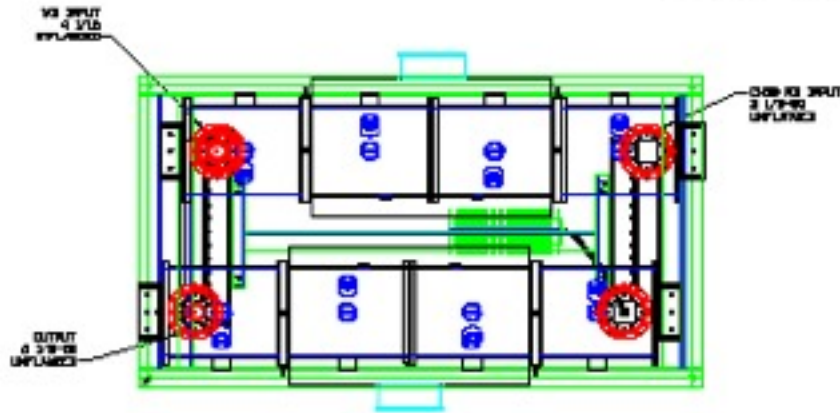

Poland Broadband Combiner

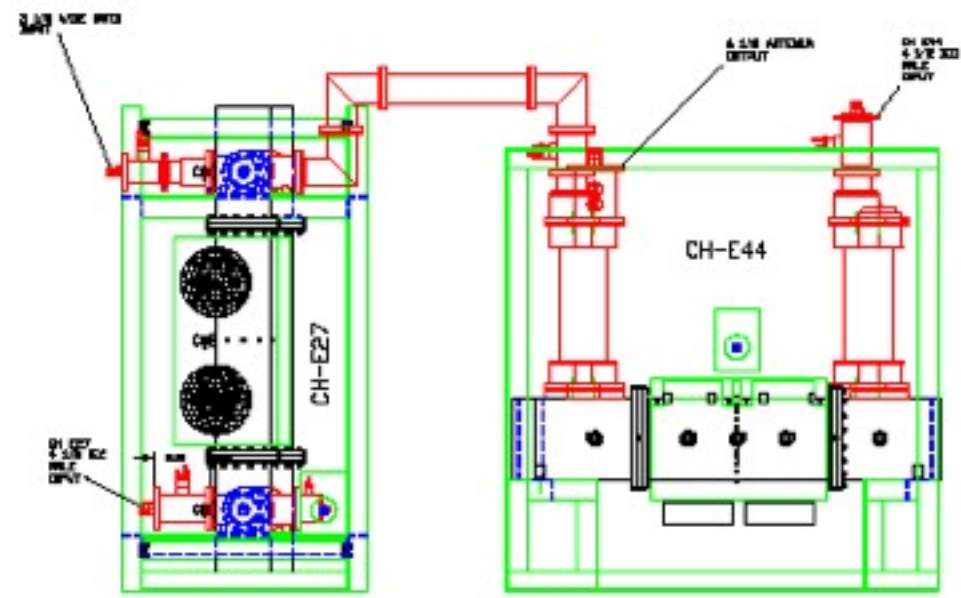
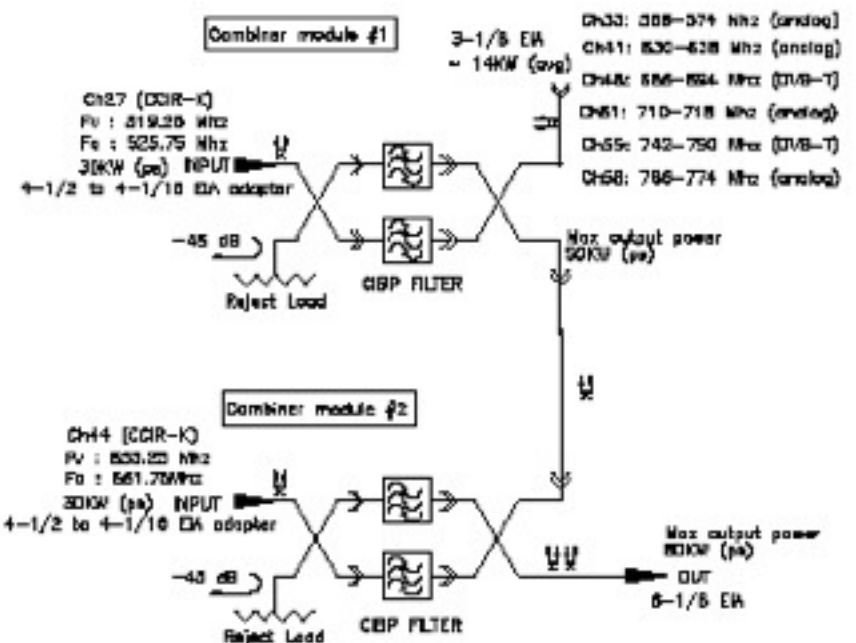
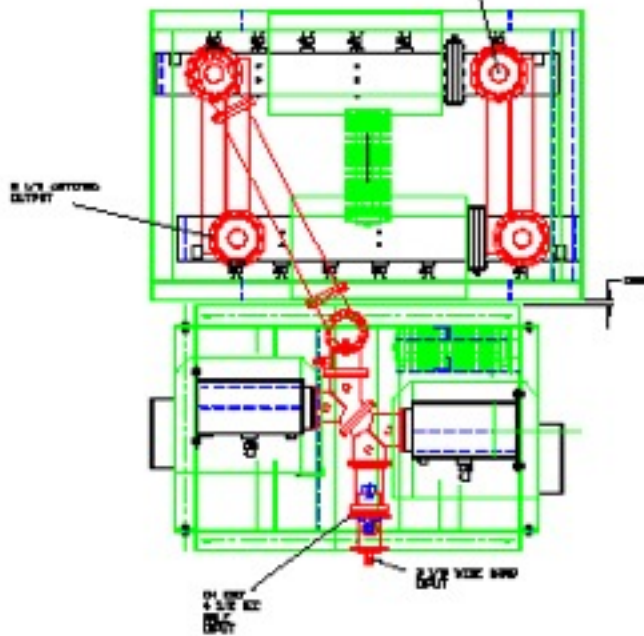

Thank you for your interest in Micro Communications



Please check out our website at www.mcibroadcast.com
for a complete copy of these presentations

Loop Combiners (Commensurate Line)

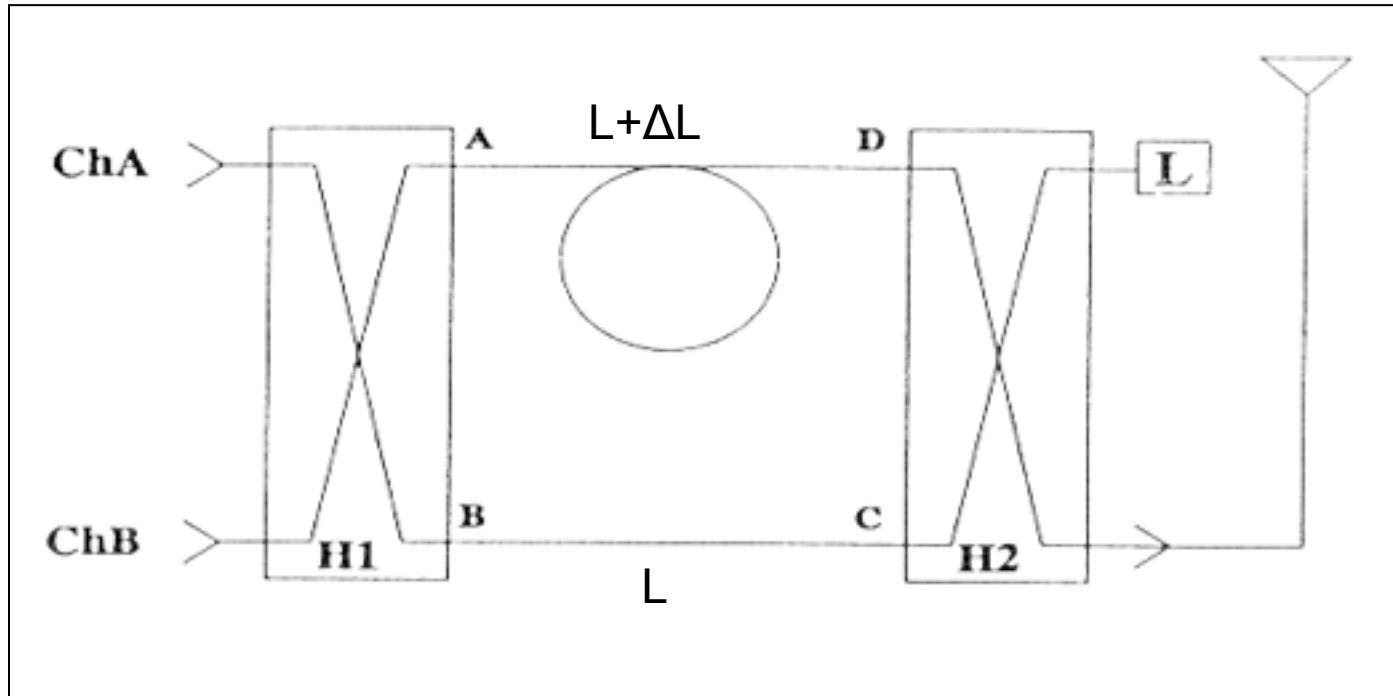

- Each channel is split by an input hybrid, phased by interconnecting cables and combined by an output hybrid.
- Proper phasing results in full transmission of both channels to the single output port.

Loop Combiners

Channel A Solutions

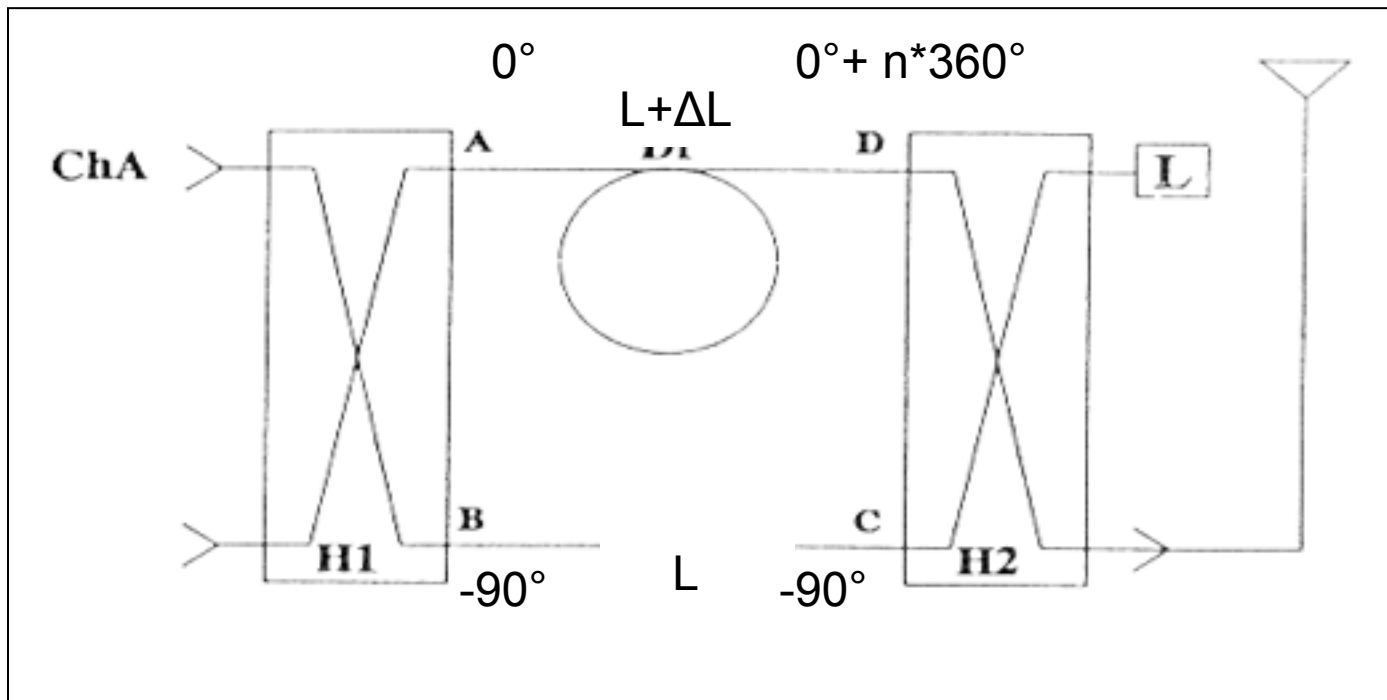

- The required differential line length for Channel A is any integer multiple of wavelength λ_A ,
$$\Delta L = n\lambda_A, \text{ where } n \text{ is any integer}$$
- This results in no change to the relative phase.

Loop Combiners

Channel B Solutions

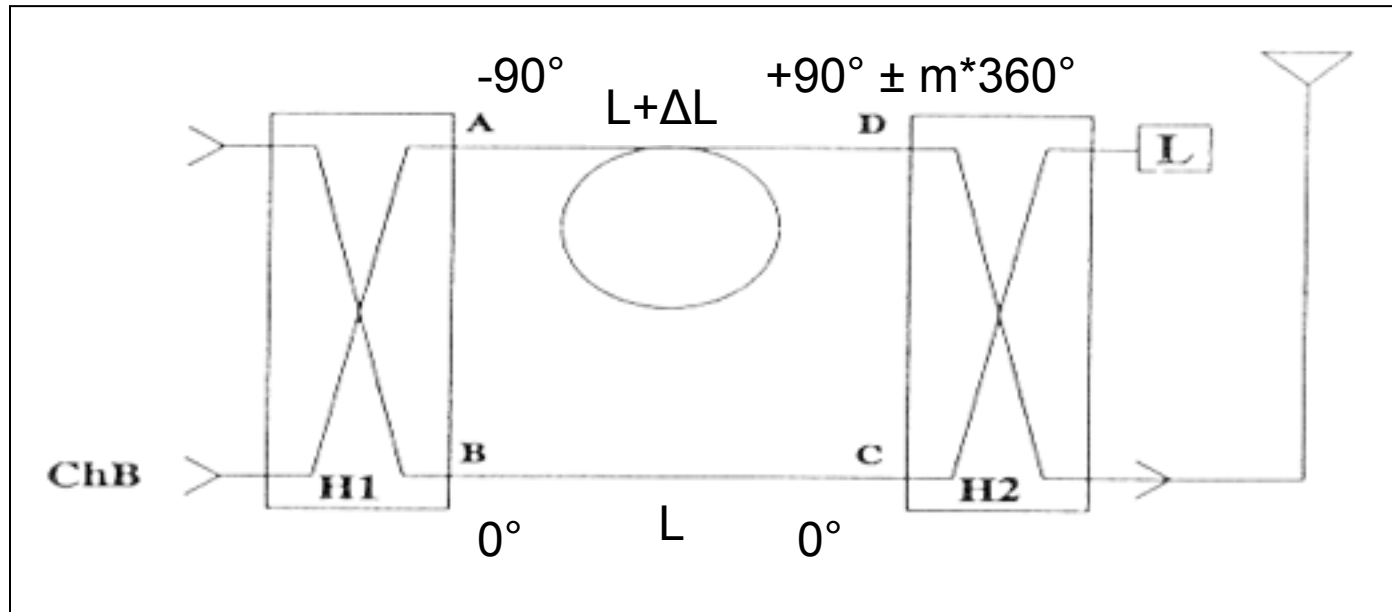

- The required differential line length for Channel B is any *odd* half-wavelength, e.g. $\lambda_B/2$, $3\lambda_B/2$, $5\lambda_B/2$, ...

$$\Delta L = (2m-1) \cdot \lambda_B/2, \text{ where } m \text{ is any integer}$$

- This inverts the relative phase, changing it by 180° .
- We can subtract 90° from the top and bottom values without changing the relative phase, resulting in

Loop Combiners

Channel B Solutions

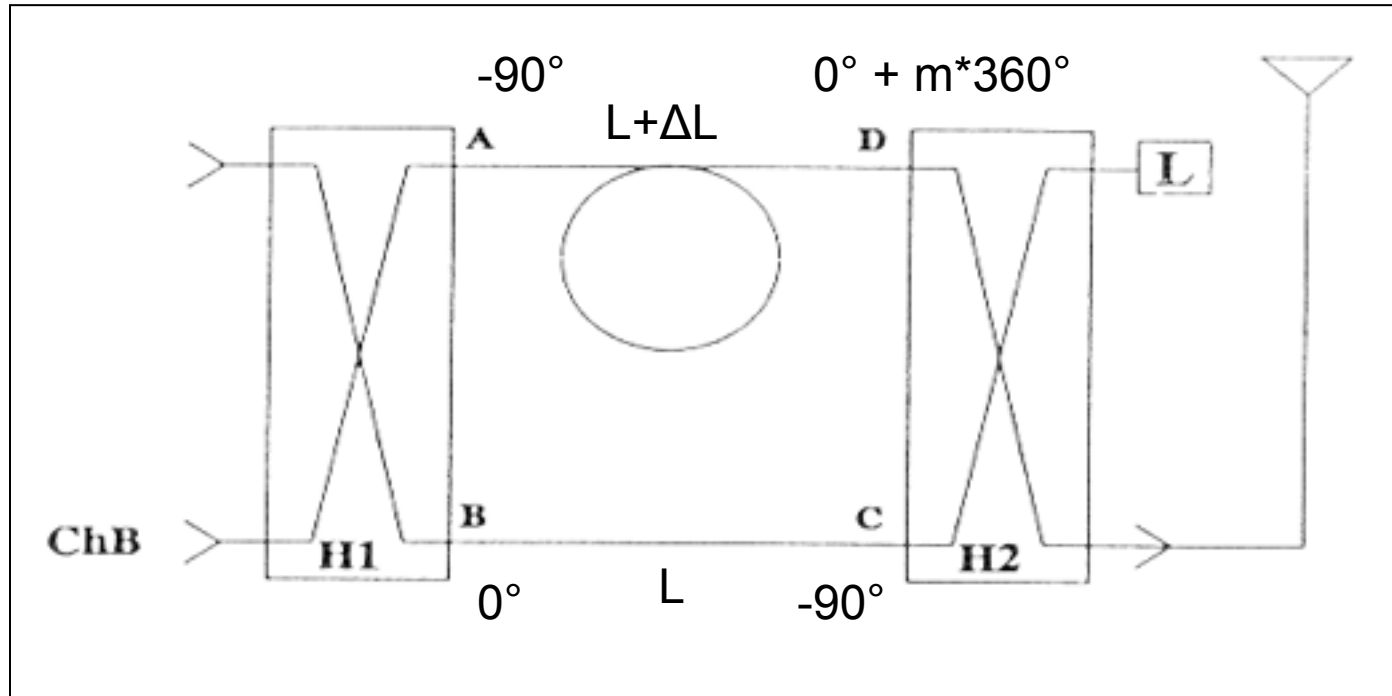

- Notice that the phase-lagging leg (upper) becomes the phase-leading leg and vice versa.
- This phases the half-signals for recombination to the antenna port

Loop Combiners

Two-Channel Solution

Two conditions govern the differential line length ΔL

$$\Delta L = n\lambda_A, \text{ where } n = 1, 2, 3, \dots$$

$$\Delta L = (2m-1)\lambda_B/2, \text{ where } m = 1, 2, 3, \dots$$

Combining these two equations we get the required relationship between integers n and m .

$$(2m-1)\lambda_B/2 = n\lambda_A$$

By dividing both sides by λ_B we get

$$m-1/2 = n (\lambda_A/\lambda_B)$$

This problem has no closed-form solution. It is solved graphically, or by computer search.

Loop Combiners

- Require no filters.
 - No group delay variations
 - Low loss, potentially very high power
- Provides no filtering.
- Very rugged and hard to detune.
- Simple to design and build.
- Limited to two, well-separated channels
- Typically more expensive than Starpoint combiners.

Loop Combiner

